



Read this Owner's Manual thoroughly before operating the equipment. Keep it with the equipment at all times. Replacements are available from Thern, Inc., PO Box 347, Winona, MN 55987, 507-454-2996. www.thern.com

IMPORTANT: Please record product information on page 2. This information is required when calling the factory for service.

ORIGINAL TEXT



Owner's Manual

For 4WM2 Series Worm Gear Hand Winch

Two-Year Limited Warranty

Please record the following:

Date Purchased: _____

Model Number: _____

Code Number: _____

This information is required when calling the factory for service.

Thern, Inc. warrants its products against defects in material or workmanship for two years from the date of purchase by the original using buyer, or if this date cannot be established, the date the product was sold by Thern, Inc. to the dealer. To make a claim under this warranty, contact the factory for an RGA number. The product must be returned, prepaid, directly to Thern, Inc., 5712 Industrial Park Road, Winona, Minnesota 55987. The following information must accompany the product: the RGA number, the date of purchase, the description of the claimed defect, and a complete explanation of the circumstances involved. If the product is found to be defective, it will be repaired or replaced free of charge, and Thern, Inc. will reimburse the shipping cost within the contiguous USA.

This warranty does not cover any damage due to accident, misuse, abuse, or negligence. Any alteration, repair or modification of the product outside the Thern, Inc. factory shall void this warranty. This warranty does not cover any costs for removal of our product, downtime, or any other incidental or consequential costs or damages resulting from the claimed defects. This warranty does not cover brake discs, wire rope or other wear components, as their life is subject to use conditions which vary between applications.

FACTORY AUTHORIZED REPAIR OR REPLACEMENT AS PROVIDED UNDER THIS WARRANTY IS THE EXCLUSIVE REMEDY TO THE CONSUMER. THERN, INC. SHALL NOT BE LIABLE FOR ANY INCIDENTAL OR CONSEQUENTIAL DAMAGES FOR BREACH OF ANY EXPRESS OR IMPLIED WARRANTY ON THIS PRODUCT. EXCEPT TO THE EXTENT PROHIBITED BY APPLICABLE LAW, ANY IMPLIED WARRANTY OF MERCHANTABILITY OR FITNESS FOR A PARTICULAR PURPOSE ON THIS PRODUCT IS LIMITED IN DURATION TO THE DURATION OF THIS WARRANTY.

Some states do not allow the exclusion or limitation of incidental or consequential damages, or allow limitations on how long an implied warranty lasts, so the above limitation or exclusion may not apply to you. This warranty gives you specific legal rights, and you may also have other rights which vary from state to state.

Note: Thern, Inc. reserves the right to change the design or discontinue the production of any product without prior notice.

About This Manual

The Occupational Safety and Health Act of 1970 states that it is the employer's responsibility to provide a workplace free of hazard. To this end, all equipment should be installed, operated, and maintained in compliance with applicable trade, industrial, federal, state, and local regulations. It is the equipment owner's responsibility to obtain copies of these regulations and to determine the suitability of the equipment to its intended use.

This Owner's Manual, and warning labels attached to the equipment, are to serve as guidelines for hazard-free installation, operation, and maintenance. They should not be understood to prepare you for every possible situation.

The information contained in this manual is applicable only to the Thern 4WM2 Series Worm Gear Hand Winch. Do not use this manual as a source of information for any other equipment.

The following symbols are used for emphasis throughout this manual:

⚠WARNING

Failure to follow 'WARNING!' instructions may result in equipment damage, property damage, and/or serious personal injury.

⚠CAUTION

Failure to follow 'CAUTION!' instructions may result in equipment damage, property damage, and/or minor personal injury.

Important!

Failure to follow 'important!' instructions may result in poor performance of the equipment.

Suggestions for Safe Operation



⚠WARNING

DO the following:

Read and comply with the guidelines set forth in this Owner's Manual. Keep this manual, and all labels attached to the winch, readable and with the equipment at all times. Contact Thern, Inc. for replacements.

Check gearbox for lubrication or leakage before use.

Install the wire rope securely to the winch drum.

Keep at least 4 wraps of wire rope wound on the drum at all times, to serve as anchor wraps. With less than 4 wraps on the drum the wire rope could come loose, causing the load to escape.

Keep hands away from the drum, wire rope, and other moving parts of the equipment.

Keep all unnecessary personnel away from the winch while in operation. Keep out of the path of the load, and out of the path of a broken wire rope that might snap back and cause injury.

DO NOT do the following:

Do not lift people, or things over people. Do not walk or work under a load or in the line of force of any load.

Do not exceed the load rating of the winch or any other component in the system. To do so could result in failure of the equipment.

Do not use more than one winch to move a load unless each winch was designed for use in a multiple winch system.

Do not use damaged or malfunctioning equipment. To do so could result in failure of the equipment.

Do not modify the equipment in any way. To do so could cause equipment failure.

Do not wrap the wire rope around the load. This damages the wire rope and could cause the load to escape. Use approved rigging connectors to secure the wire rope to the load.

Do not lift loads or pull loads on an incline unless the winch is equipped with a load brake.

Do not divert your attention from the operation. Stay alert to the possibility of accidents, and try to prevent them from happening.

Do not jerk or swing the load. Avoid shock loads by starting and stopping the load smoothly. Shock loads overload the equipment and may cause damage.

Do not leave a suspended load unattended unless specific precautions have been taken to secure the load and keep people away from the winch and from under the load.

Do not adjust the winch brake with the load suspended.

Do not exceed the duty cycle rating of the winch when operating with a drill-motor, and do not operate the winch with a drill-motor that exceeds 400 rpm or an impact wrench. To do so could result in equipment damage or failure. See Figure 1.

Figure 1 – Duty Rating

Model	Winch Duty Cycle Rating with Drill-Motor
4WM2	15 minute

Do not continue to operate winch with drill-motor if gearbox or brake show signs of overheating.

Allow winch to cool to ambient temperature before continuing operation.

1.1 Installing the Winch

Important!

- Inspect the winch immediately following installation according to the Instructions for Periodic Inspection. This will give you a record of the condition of the winch with which to compare future inspections.
- A qualified professional should inspect or design the foundation to insure that it will provide adequate support.
- Locate the winch so it will be visible during the entire operation.
- Do not weld the winch frame to the foundation or support structure. Welding the frame may void warranty, contact factory. Use fasteners as instructed.

⚠WARNING

Do not install the winch in an area defined as hazardous by the National Electric Code, unless installation in such an area has been thoroughly approved.

Do not install the winch near corrosive chemicals, flammable materials, explosives, or other elements that may damage the winch or injure the operator. Adequately protect the winch and the operator from such elements.

Position the winch so the operator can stand clear of the load, and out of the path of a broken wire rope that could snap back and cause injury.

Attach the winch to a rigid and level foundation that will support the winch and its load under all load conditions, including shock loading.

- 1.1.1 CONSULT APPLICABLE CODES AND REGULATIONS for specific rules on installing the equipment.
- 1.1.2 LOCATE THE WINCH in an area clear of traffic and obstacles. Make sure the winch is accessible for maintenance and operation.
- 1.1.3 LOCATE THE WINCH in an area with adequate temperatures. The winch is rated for operation in ambient temperatures ranging from 0° to 100° F.
- 1.1.4 POSITION THE WINCH to allow access for proper lubrication.
- 1.1.5 MAINTAIN A FLEET ANGLE between 1/2 and 1-1/2 degrees. The proper fleet angle minimizes wire rope damage by helping the wire rope wind uniformly onto the drum. See Figure 2.
- 1.1.6 FASTEN THE WINCH SECURELY to the foundation.
 - a FOR STANDARD PRODUCTS referred to in this manual, use 3/8 inch coarse thread fasteners, grade 5 or better, torqued dry to 30 ft-lbs without lubrication. Make sure the winch frame is secured to a solid foundation able to support the winch and the load under all conditions with design factors based on accepted engineering practices.
 - b NON-STANDARD PRODUCTS that vary from the original design may have different fastening requirements. Contact a structural engineer or Thern, Inc. for this information.

TO COMPLY WITH LOCAL CODES, CONTACT A QUALIFIED PROFESSIONAL TO OBTAIN PROPER STRUCTURE OR FOUNDATION SPECIFICATIONS FOR THE MOUNTING OF THERN PRODUCTS.

1.2 Installing the Breather Plug

Important!

- Save the extra oil plug for use when the winch is removed for storage or transport.

CAUTION

Install the breather plug to vent heat and pressure from the gearbox. Failure to do so could result in pressure buildup which could damage the equipment.

For shipment, the gearbox is sealed with an oil plug, and the breather plug is attached to the gearbox or shipped in a separate envelope.

1.2.1 REMOVE THE OIL PLUG and install the breather plug in the proper location. Make sure the breather plug is above the level of the oil. See Figure 3.

1.2.2 CHECK THE OIL LEVEL in the gearbox to make sure no oil was lost during shipment. See Section 3.3 Lubricating the Winch.

Install the breather plug to vent heat and pressure from the gearbox. Failure to do so could result in pressure buildup which can cause the gearbox to leak or damage the equipment.

Important!

- Use a sheave or roller guide to direct the wire rope to the drum whenever possible.
- Install sheaves, tracks and other equipment so they will remain fixed under all load conditions. Follow the recommendations of the equipment manufacturer.
- Use sheaves of proper diameter to minimize wear on the wire rope. Follow the recommendations of the sheave manufacturer.

Figure 2 – Maintaining the Fleet Angle

- **When wire rope travels over a sheave or through a roller guide – maintain fleet angle by locating the sheave or guide an appropriate distance from the drum, shown as distance “A”.**

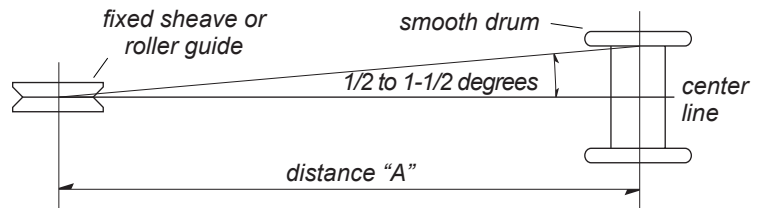

- **When wire rope travels directly to the load – maintain fleet angle by controlling side-to-side movement of the load with tracks or guide rails. Allowing the load to move too far to one side causes stress on the drum flange which may cause damage.**

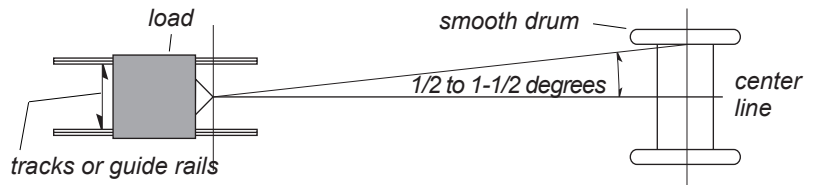
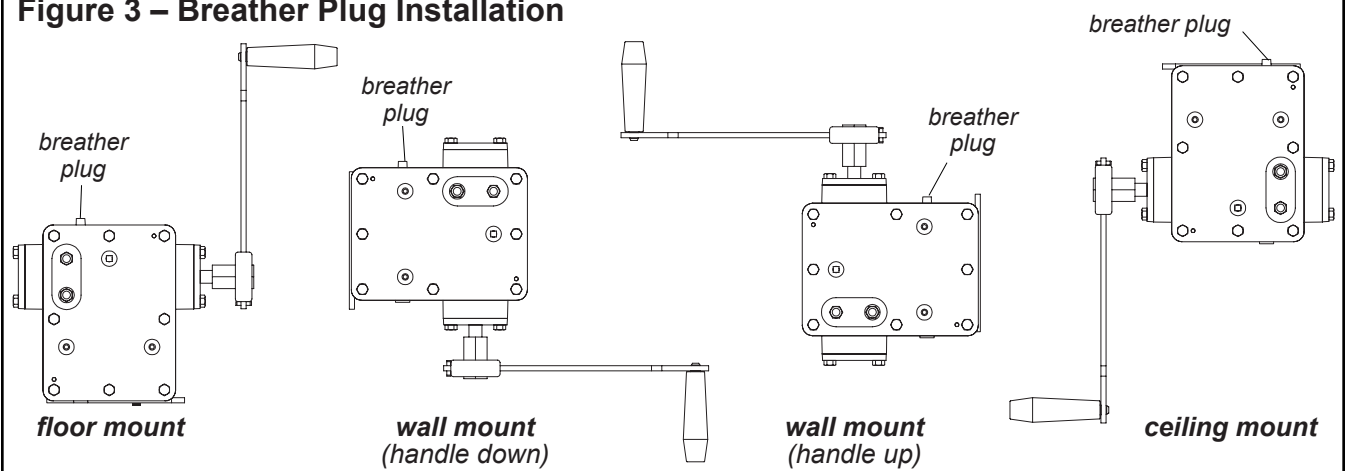
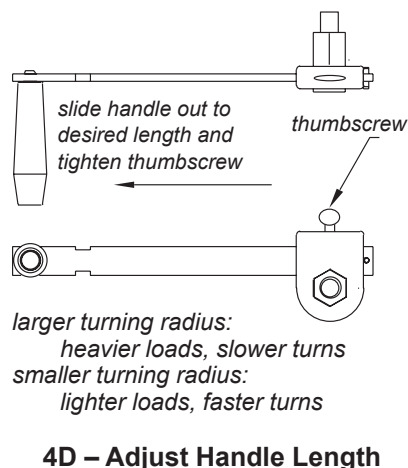
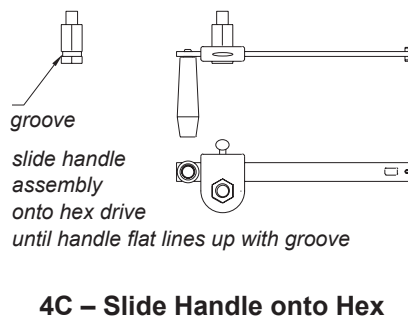
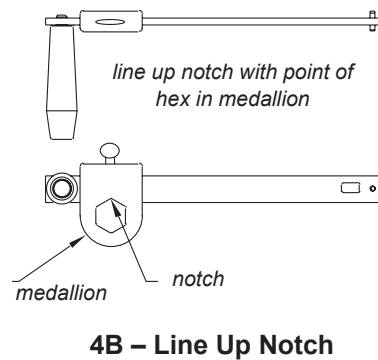
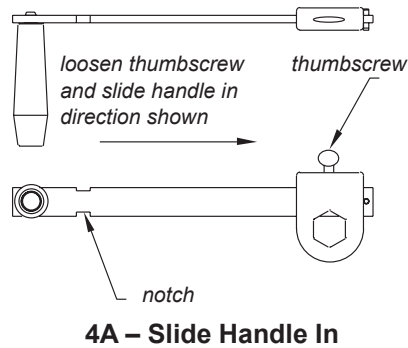

Figure 3 – Breather Plug Installation



1.3 Installing the Handle

Figure 4 – Installing the Handle



The winch includes a 1-1/8 inch hex drive input. You can attach the handle to this input, or you can use a 1-1/8 inch hex socket to power drive the winch with a maximum 400 rpm drill-motor. **Remove the handle before power driving the winch with a drill-motor.**

- 1.3.1 LOOSEN THE THUMBSCREW and slide the handle toward the medallion as shown. See 4A.
- 1.3.2 LINE UP THE NOTCH in the handle with the point of the hex in the medallion. See 4B.
- 1.3.3 SLIDE THE HANDLE AND MEDALLION ASSEMBLY onto the hex drive until the flat of the handle lines up with the groove in the hex drive. See 4C.
- 1.3.4 SLIDE THE HANDLE outward away from the medallion to the desired length and tighten the thumbscrew. See 4D.

1.4 Installing the Wire Rope

Important!

- Use wire rope and other rigging equipment rated for the largest load you will be moving.
- Do not drag the wire rope through dirt or debris that could cause damage, or poor operation.
- Always wear protective clothing when handling wire rope.

⚠WARNING

Install the wire rope securely to the winch drum. A poorly secured wire rope could come loose from its anchor and allow the load to escape.

Do not use 3/16 inch or smaller wire rope on standard drums. To do so could cause damage to the wire rope and allow the load to escape.

Install the wire rope so it is wound correctly as shown or the winch and brake will not work properly, and could allow the load to escape, see Figure 5.

Figure 5 – Installing the Wire Rope

install the wire rope so it is underwound on the drum as shown

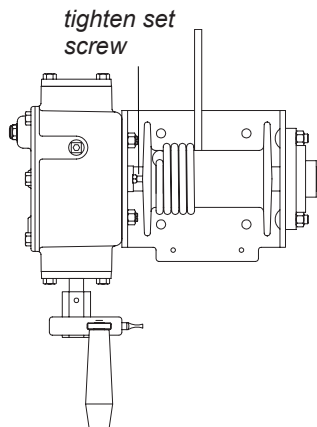

Wire rope assemblies with anchor fittings can be purchased from Thern, Inc.

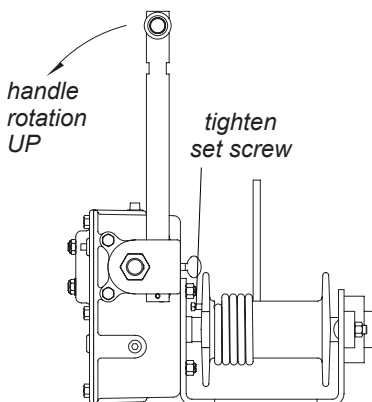

typical installation shown left lay – underwound

- 1.4.1 PURCHASE THE PROPER WIRE ROPE for your application. Keep the following in mind when selecting a wire rope. Contact a reputable wire rope supplier for help.
 - a BREAKING STRENGTH of new wire rope should be at least 3 times greater than the largest load placed on the winch. If loads are lifted or pulled on an incline, the breaking strength must be at least 5 times greater than the largest load. These are minimum values and will vary with the type of load and how you are moving it.
 - b WIRE ROPE LAY must agree with the winding direction of the drum to help insure proper winding.
 - c WE RECOMMEND 7x19 galvanized aircraft wire rope for diameters up to 5/16 inch. **Do not use 3/16 inch or smaller wire rope for units with standard drums.**
- 1.4.2 ANCHOR THE WIRE ROPE to the drum using either the set screw or quick disconnect anchor.
 - a SET SCREW ANCHOR. See Figure 5.
 - PASS THE WIRE ROPE under the drum from the front and position it in the slot in the drum. Make sure at least 1/2 inch of wire rope extends past the set screw, and the end of the wire rope does not protrude out where it will interfere with wire rope winding onto the drum.
 - TIGHTEN THE SET SCREW to hold the wire rope in place. Hold the wire rope down while tightening so the wire rope does not push up out of the slot.
 - b QUICK DISCONNECT ANCHOR. See Figure 5.
 - PASS THE WIRE ROPE under the drum from the front and position the anchor fitting in the groove in the drum.
 - PULL THE WIRE ROPE to firmly lodge the anchor fitting in place.
- 1.4.3 TURN THE HANDLE COUNTER-CLOCKWISE to wind wire rope onto the drum. If wire rope unwinds from the drum when the handle is rotated counter-clockwise, the wire rope is installed incorrectly. **Install the wire rope correctly before continuing. See Figure 5.**
- 1.4.4 WIND FOUR FULL WRAPS of wire rope onto the drum by operating the winch while holding the wire rope taut. **These wraps serve as anchor wraps and must remain on the drum at all times.**

CONTACT A REPUTABLE WIRE ROPE SUPPLIER FOR HELP.

2.1 General Theory of Operation

Important!

- Limit nonuniform winding by keeping tension on the wire rope and by maintaining the proper fleet angle.
- It is your responsibility to detect and account for different factors affecting the condition and performance of the equipment.

- 2.1.1 THE FORCE REQUIRED to move the load must not exceed the load rating of the winch. Consider the total force required to move the load, not the weight of the load.
- 2.1.2 THE AMOUNT OF TIME required to move the load must not exceed the 15 minute duty cycle rating of the winch, when operating with a drill-motor.
- 2.1.3 THIS EQUIPMENT CAN develop forces that will exceed the load rating. It is the responsibility of the equipment user to limit the size of the load. Inspect the equipment regularly for damage according to the instructions contained in this manual and in component manufacturer's information.
- 2.1.4 USE A LOAD BRAKE on all winches used to lift loads or pull loads on an incline. Although a new winch may appear to hold the load in place, this characteristic will diminish with use. **Do not depend on gearing to hold the load in place.**
- 2.1.5 PERFORMANCE RATINGS of the equipment are affected by the amount of wire rope wound on the drum, the way in which it is wound, and the way the winch is used.
- DRUM CAPACITY depends on how tightly and evenly the wire rope is wound on the drum. Actual drum capacities are usually 25-30% less than values shown in performance Tables, due to loose winding and overlapping.
 - FORCE REQUIRED TO LIFT the load increases with each additional layer of wire rope wound onto the drum. The value shown in performance Tables is based on an empty drum, and maximum handle length.
 - LOAD RATING represents the maximum pull that can be placed on new equipment. Load ratings are assigned values for specific amounts of load travel or wire rope accumulation. The load rating decreases as layers of wire rope accumulate on the drum.
- 2.1.6 DUTY RATINGS refer to the type of use the equipment is subject to. Consider the following when determining duty rating. The winch has a 15 minute duty cycle rating, when operating with a drill-motor.
- ENVIRONMENT: harsh environments include hot, cold, dirty, wet, corrosive, or explosive surroundings. **Protect the equipment from harsh environments when possible.**
 - MAINTENANCE: poor maintenance, meaning poor cleaning, lubrication, or inspection, leads to poor operation and possible damage of the equipment. **Minimize poor maintenance by carefully following the instructions contained in this manual.**
 - LOADING: severe loading includes shock loading and moving loads that exceed the load rating of the equipment. **Avoid shock loads, and do not exceed the load rating of the equipment.**
 - FREQUENCY OF OPERATION: frequent or lengthy operations increase wear and shorten the life span of gears, bearings, and other components. **Increase maintenance of the equipment if used in frequent operations. Length of operation should not exceed 15 minute duty cycle rating when operating with a drill-motor.**

CONTACT THE FACTORY FOR MORE INFORMATION.

2.2 Breaking-In the Winch

- 2.2.1 BREAK-IN OCCURS during the first 10 hours of normal operation. During break-in, mating surfaces become polished, and clearances increase. This is desired for efficient operation of bearings and gears.
- 2.2.2 INSPECT THE WINCH following break-in according to the Instructions for Periodic Inspection. See section 3.4 Inspecting the Equipment.

2.3 Preparing for Operation

Important!

- When determining whether the load will exceed the load rating, consider the total force required to move the load.

- 2.3.1 CONSIDER THE OPERATION. Do not begin until you are sure you can perform the entire operation without hazard.
- 2.3.2 BEFORE EACH OPERATION inspect all components of the system.
- INSPECT THE WINCH and other equipment according to the Instructions for Frequent Inspection. Do not operate winch until all defects have been corrected.
 - OPERATORS must be in good health, alert, and thoroughly trained in operating the equipment, and properly clothed (safety equipment as required, no loose clothing, no loose jewelry).
 - THE LOAD must be clear of other objects and free to move. Make sure the load will not tip, bind, or in any way move uncontrollably.
- 2.3.3 KNOW YOUR LOAD and make sure you do not exceed the load rating of the winch or other equipment in the system.

2.4 Attaching the Load

⚠WARNING

Do not wrap the wire rope around the load. This damages the wire rope and could cause the load to escape. Use a sling or other approved lifting device.

- 2.4.1 CLEAR OBJECTS from the path of the load so you can move it freely and observe it at all times during the operation.
- 2.4.2 ATTACH THE LOAD using a nylon sling, or other approved rigging device. Follow the recommendations of the sling manufacturer.
- SEAT THE SLING in the saddle of the hook with the hook latch completely closed. See Figure 6.
 - CENTER THE LOAD on the hook so it will remain balanced and not tip or rotate to one side.

Figure 6 – Attaching Load

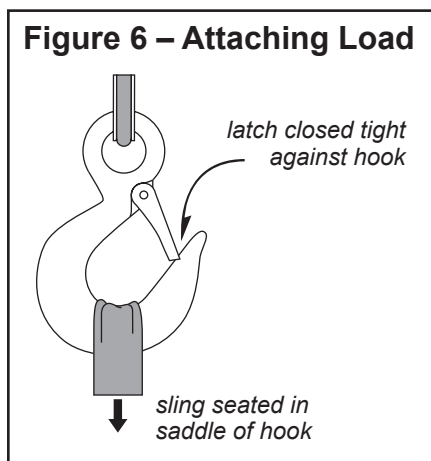

2.5 Moving the Load

Important!

- Obey a stop signal from anyone.
- Maintain tension on the wire rope to keep it tightly and evenly wound on the drum.
- If the winch and load are not visible during the entire operation, get help from another person.
- Appoint a supervisor if more than one person is involved in the operation. This will reduce confusion and increase safety.
- Remove the winch handle and secure the drum using the drum lock when the winch is not in use, to help avoid unauthorized use.

Figure 7 – Operation

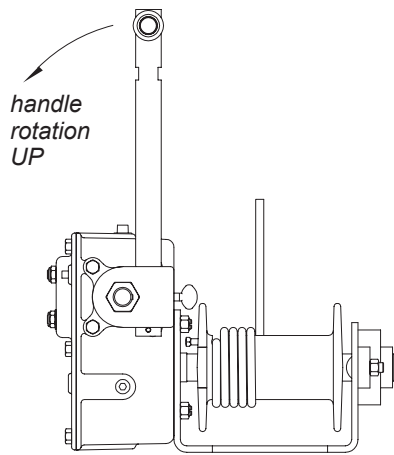

- 2.5.1 MOVE THE LOAD slowly and smoothly, only a small distance at first. Make sure the load is balanced and securely attached before continuing.
- 2.5.2 TURN THE HANDLE COUNTER-CLOCKWISE to wind wire rope onto the drum. If wire rope unwinds from the drum when the handle is rotated counter-clockwise, the wire rope is installed incorrectly. **Install the wire rope correctly before continuing. See Figure 7.**
- 2.5.3 GRIP THE HANDLE TIGHTLY at all times during operation. If you release the handle the load may backdrive causing the handle to spin. **Do not try to stop a spinning handle, step clear until the spinning stops.**
- 2.5.4 OBSERVE THE WIRE ROPE as it winds onto the drum. If it becomes loose, uneven, or overlapped, stop the operation and rewind the wire rope before continuing. **Continued operation with overlapped or uneven wire rope can damage the wire rope and shorten its life.**
- 2.5.5 FOLLOW THE GUIDELINES BELOW to operate the winch with a drill-motor.
- DO NOT EXCEED THE DUTY CYCLE RATING of the winch when operating with a maximum 400 rpm drill-motor. See Figure 1.**
 - ALLOW THE WINCH AND BRAKE TO COOL DOWN to ambient temperature in rest periods between operations.
 - USE A MAXIMUM 400 RPM DRILL -MOTOR with a 1-1/8 inch hex socket to power drive the input shaft on the winch. The drill-motor should be set for low speed operation if possible. Thern recommends using a drill-motor rated for 400 rpm at 10 amps.
 - THE LOAD RATING OF THE WINCH may decrease when operated with a drill-motor. Check the winch nameplate.
- 2.5.6 OBSERVE THE GEARBOX AND BRAKE during operation for signs of overheating. **Frequent overheating may be a sign of damage, or may indicate the need for a larger winch.**
- WATCH FOR SMOKE, the smell of burnt lubricant, and other signs of overheating. Use a thermocouple or other device to monitor gearbox and brake temperature. The temperature of the gearbox should not exceed 150° F.
 - STOP THE OPERATION if the gearbox or brake overheats, and allow the winch to cool until it reaches ambient temperature. **Continued operation may cause damage.**

Important!

Increase the frequency of maintenance procedures if the winch is:

- Operated frequently.
- Used to pull heavy loads.
- Operated in wet, dirty, hot, or cold surroundings.

3.1 Cleaning the Winch

Clean the winch to remove dirt and help prevent rust and corrosion.

- 3.1.1 CLEAN THE WINCH every 6 months or whenever it is dirty.
 - a WIPE ALL EQUIPMENT to remove dirt and grease.
 - b LEAVE A LIGHT FILM of oil on all surfaces to protect them against rust and corrosion.
 - c WIPE OFF excessive amounts of oil to avoid the accumulation of dirt.
- 3.1.2 REMOVE all unnecessary objects from the area surrounding the winch.

3.2 Adjusting the Brake

Important!

- Do not over tighten the brake, since this will cause parts to wear and become damaged.

⚠WARNING

Do not adjust the brake with the load suspended. Accidental release of the brake could allow the load to escape.

Figure 8 – Adjusting the Brake

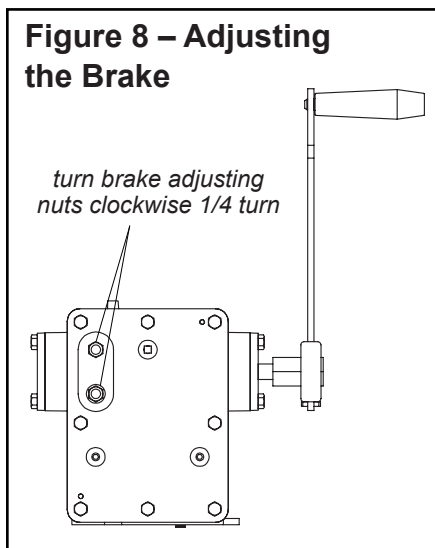

- 3.2.1 ADJUST THE BRAKE whenever it appears to need adjustment, or at least every 3 months.
- 3.2.2 TO CHECK THE BRAKE on the 4WM2 series by operating with a test load equal to the winch load rating:
 - a RAISE THE LOAD, then lower it and stop it about one foot off the ground.
 - b OBSERVE THE LOAD when stopped. If it continues to coast or creep, the brake needs adjustment. Contact the factory for assistance.
 - FOR MANUALLY OPERATED WINCHES, adjust the brake nuts according to the input shaft torque range specified for the winch, turning the nuts clockwise by 1/4 turns between torque readings. See Table 1. **Do not adjust the brake with the load suspended.**
 - **DO NOT OVERTIGHTEN** mechanical brake adjusting nuts.
- 3.2.3 TIGHTEN THE BRAKE by turning the adjusting nuts clockwise about 1/4 turn. Continue to test and tighten the brake by alternate tightening of each brake nut until it stops and holds the load securely. See Figure 8.
- 3.2.4 A DECELERATION DISTANCE while stopping is typically 6 inches.
- 3.2.5 IF THE LOAD CONTINUES TO COAST or creep, contact the factory.

Table 1 – Torque¹ While Lowering for 4WM2 Units

Unit	Under No Load	Under Load	Direction ²
4WM2	2-4 ft-lbs	4-10 ft-lbs	clockwise

¹ Do not adjust brake with load suspended.

² Complete 1 full rotation of input shaft.

³ Tighten brake until the minimum value is obtained. See Figure 8.

3.3 Lubricating the Winch

Important!

- Do not leave plug holes in the gearbox open. Open plug holes will allow dirt or moisture to contaminate the grease.
- Make sure lubricant has a temperature rating appropriate for the ambient temperatures of the operation.

CAUTION

Make sure the breather plug is clean and open to vent heat and pressure. Poor ventilation may cause overheating and result in equipment damage.

Check the gearbox for proper oil level before operation. Too much or too little oil will cause overheating and result in equipment damage.

Lubricate the winch properly to help protect it from wear and rust. Read the following instructions carefully.

3.3.1 THE WINCH IS SHIPPED from the factory with the proper amount (44 ounces) of Mobilgear 600 XP 220 lubricant in the gearbox. Lubricate the winch as follows, see Figures 9 and 10.

3.3.2 CHECK OIL LEVEL before every operation and every 10 hours during operation. Remove the level check plug and make sure oil is even with the plug hole. Add oil to the gearbox if necessary. **Do not use synthetic lubricants and do not mix different lubricants. See Figure 10.**

3.3.3 CHANGE GEARBOX OIL at least every 6 months, or whenever it is dirty or contaminated. Remove the drain plug to drain oil from the gearbox. See Figure 10.

3.3.4 LUBRICATE THE OUTBOARD BEARING at least once every month or more, depending on usage. Use a grease gun to insert NLGI no. 2 grease until clean grease appears at the seals. The bearing will squeak if it is dry. See Figure 9.

3.3.5 LUBRICATE THE WIRE ROPE and other equipment by following the manufacturer's recommendations.

Figure 9 – Outboard Bearing

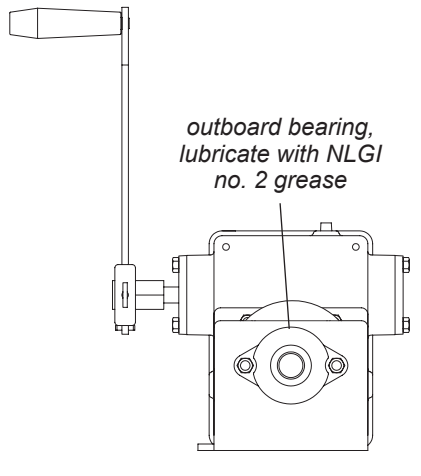
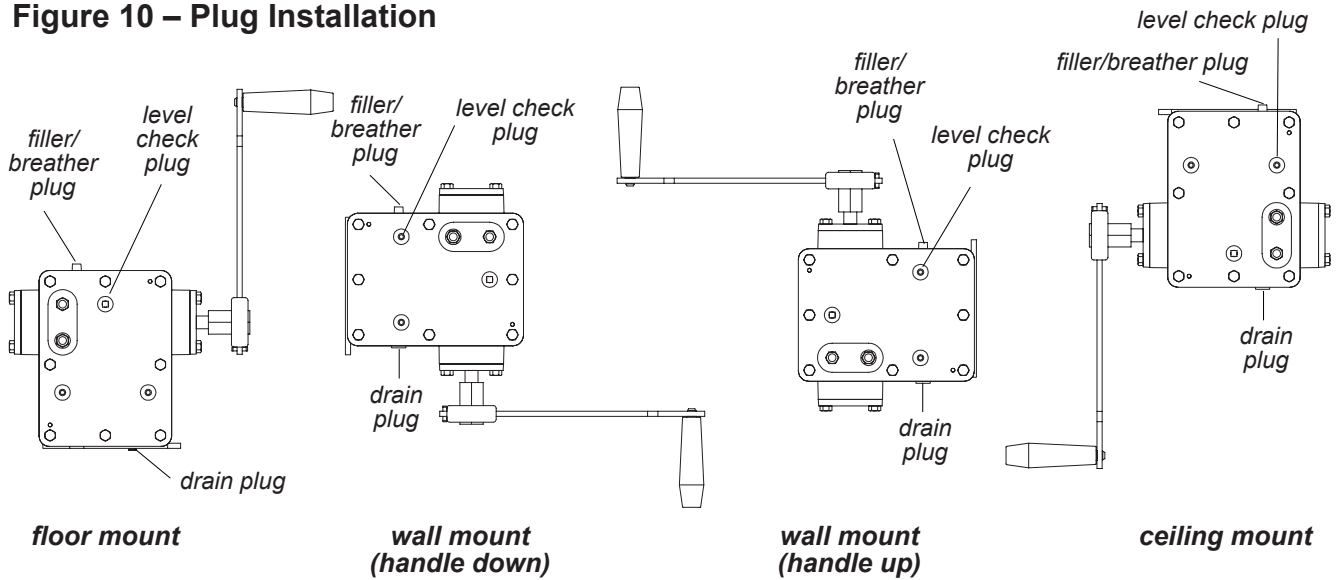

Figure 10 – Plug Installation



3.4 Inspecting the Equipment

Important!

- Start an inspection program as soon as you put the winch into use.
- Appoint a qualified person to be responsible for regularly inspecting the equipment.
- Keep written records of inspection. This allows comparison with comments from previous inspections so you can see changes in condition or performance.

Perform frequent inspections:

- Before each operation.
- Every 3 hours during operation.
- Whenever you notice signs of damage or poor operation.

Frequent Wire Rope Inspection:

- Use ASME B30.7 as a guideline for rope inspection, replacement and maintenance.
- Check the wire rope, end connections and end fittings for corrosion, kinking, bending, crushing, bird-caging or other signs of damage.
- Check the number, distribution and type of visible broken wires. See paragraph 3.4.4 c and Figure 11.
- Check the wire rope for reduction of rope diameter from loss of core support, or wear of outside wires. See Figure 13.
- Take extra care when inspecting sections of rapid deterioration such as sections in contact with saddles, sheaves, repetitive pickup points, crossover points and end connections.

⚠WARNING

Do not use damaged or malfunctioning equipment. Place an “OUT OF ORDER” sign on the winch. Do not use the winch until the sign is removed by a qualified maintenance person who has completely corrected the problem.

Inspect the winch to detect signs of damage or poor operation before they become hazardous. See Table 2 - Inspection Checklist.

3.4.1 CONSULT APPLICABLE CODES AND REGULATIONS for specific rules on inspecting the winch and other equipment.

3.4.2 CONSULT MANUFACTURER’S RECOMMENDATIONS for information on inspecting the wire rope and other equipment.

3.4.3 Instructions for Frequent Inspection

- a VISUALLY INSPECT the entire winch and all other equipment involved in the operation.
 - Check all equipment for cracks, dents, bending, rust, wear, corrosion and other damage.
 - Make sure the wire rope is installed correctly and anchored securely to the drum.
 - Make sure the winch is properly lubricated.
 - Make sure the thumbscrew holding the handle in place is tight.
 - Check the gearbox for signs of leakage, and make sure it is filled with the proper lubricant. Contact the factory if there are any signs of lubricant leaking from the gearbox.
 - Make sure the breather plug is clean, open, and installed correctly.
 - Make sure mounting fasteners are tightened securely.
 - Make sure the foundation is in good condition, and capable of supporting the winch and its load under all load conditions.
- b TEST WINCH PERFORMANCE by moving the winch with a load not exceeding the load rating.
 - Listen for unusual noises, and look for signs of damage as you operate the winch.
 - Make sure the wire rope winds evenly and tightly onto the drum. If it is loose or uneven, rewind it before continuing.
 - Make sure the load moves smoothly, without hesitation or strain.
 - Make sure the handle rotates freely in both directions.
 - Check the brake. Raise the load, then lower it and stop it a few feet off the ground. If the load continues to coast or creep under normal operating conditions, the brake needs adjustment. See section 3.2 Adjusting the Brake.

Completely correct all problems before continuing. Use the Troubleshooting Chart to help determine the cause of certain problems. See Table 3.

Perform periodic inspections:

- Every 6 months, or more frequently if drill driven.
- Whenever you return the winch to service from storage.
- Whenever you notice damage or poor operation in a frequent inspection.
- Whenever you have, or think you may have, overloaded or shock loaded the winch.

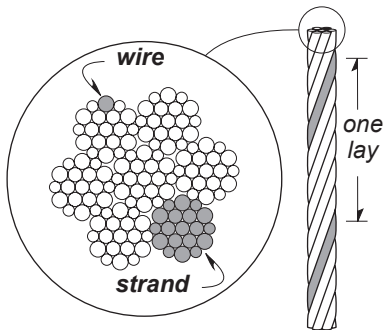
Figure 11 – Broken Wires

Wire rope assembly must be replaced if more than 6 wires are broken in one lay, or if more than 3 wires are broken in one strand in one lay.

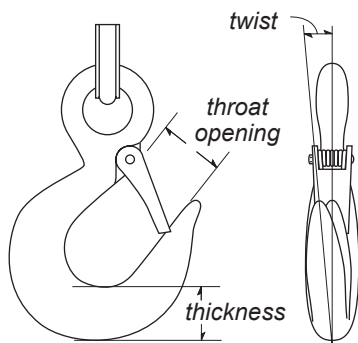
Figure 12 – Load Hook Inspection

The wire rope assembly must be replaced if the throat opening is 15% wider than nominal, if the thickness is 10% less than nominal, or if the hook is twisted 10° or more.

3.4.4 Instructions for Periodic Inspection

- VISUALLY INSPECT** the winch and all other equipment.
 - Disassembly may be required in order to properly inspect individual components. Contact factory for assembly/disassembly instructions. Disassembly of the gearbox before contacting Thern, Inc voids all warranties.
 - Check the finish for wear, flaking, or other damage.
 - Check all equipment for cracks, dents, bending, rust, wear, corrosion and other damage. If the equipment was overloaded, or if you notice cracks and other signs of overloading and damage promptly remove equipment from use and have it repaired or replaced. **DO NOT CONTINUE TO USE DAMAGED OR OVERLOADED EQUIPMENT OR WIRE ROPE.**
 - Check all fasteners for stripped threads, wear, bending, and other damage.
 - Check the gearbox for signs of leakage. Contact factory if there are any signs of lubricant leaking from the gearbox.
 - Make sure the breather plug is clean, open, and installed correctly.
 - Make sure all labels and plates are readable, firmly attached, free of damage and clean. Replacements are available from the factory.
 - Check the foundation for cracks, corrosion, and other damage.
- DRAIN A SMALL AMOUNT OF OIL** into a clean container.
 - Check the oil for dirt, metal particles, water, and other signs of contamination. Completely drain the gearbox if oil is contaminated.
 - Make sure the gearbox is properly lubricated. See section 3.3 Lubricating the Winch.
- INSPECT THE WIRE ROPE** according to the wire rope manufacturer's recommendations or follow accepted industry standards for wire rope inspection.
 - Always wear protective clothing when handling wire rope.
 - Check the entire length of wire rope for bent wires, crushed areas, broken or cut wires, corrosion, and other damage. Carefully inspect areas that pass over sheaves or through roller guides.
 - Note the location and concentration of broken wires. Replace wire rope if more than 6 wires are broken in one lay, or more than 3 wires are broken in one strand in one lay. See Figure 11.
 - Make sure the load hook, anchor fitting, or other devices are securely attached to the wire rope, and the wire rope where they are attached is not frayed, corroded, broken, or otherwise damaged.
 - Measure the throat opening, thickness, and twist of the hook. Replace the hook if it shows signs of damage. See Figure 12.
 - Make sure hook latch opens without binding and closes when released.
 - Check the anchor holes in the drum and the surrounding area for signs of wear or distortion.

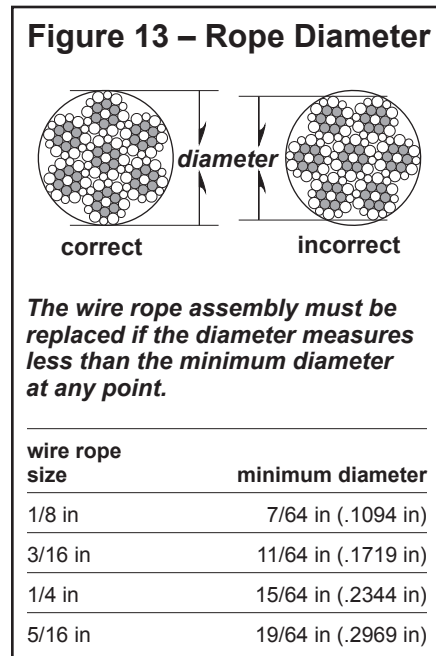

- d MOVE THE DRUM with your hands.
 - Check for excessive movement indicating worn or loose gears, bearings, or shafts. Slight endplay in the driveshaft is normal. Excessive movement is caused by overloading or overheating, and is a sign that your application may require a larger winch.
 - Disassemble the winch if necessary. Inspect gears, keys, bearings, seals, and shafts for wear, corrosion, distortion, and other damage. Contact factory for assembly/disassembly instructions. Disassembly of the product before contacting Thern, Inc. voids all warranties.
- e PLACE enough weight to keep the wire rope straight and tightly drawn.
 - Measure the diameter of the wire rope, especially in areas where wear is noticeable. Replace the wire rope if the diameter measures below the minimum diameter at any point. See Figure 13.
- f LUBRICATE THE ENTIRE WINCH.
- g INSTALL THE WIRE ROPE.
- h TEST WINCH PERFORMANCE by operating the winch with a load equal to the load rating.
 - Listen for unusual noises, and look for signs of damage as you operate the winch.
 - Make sure the wire rope winds evenly and tightly onto the drum. If it is loose or uneven, rewind it before continuing.
 - Observe the rotating drum, look for signs of loose or misaligned bearings.
 - Make sure the load moves smoothly, without hesitation or strain.
 - Make sure the handle rotates freely in both directions.
 - Check the brake. Raise the load, then lower it and stop it a few feet off the ground. If the load continues to coast or creep under normal operating conditions, the brake needs adjustment. See section 3.2 Adjusting the Brake.

Completely correct all problems before continuing. Use the troubleshooting chart to help determine the cause of certain problems. See Table 3.

Table 2 – Inspection Checklist

checked boxes indicate damage or problem in need of repair

	damages	problems
general	<input type="checkbox"/> finish weathered, flaking, otherwise damaged <input type="checkbox"/> parts cracked, bent, rusted, worn, otherwise damaged	<input type="checkbox"/> winch jerks or hesitates during operation <input type="checkbox"/> unusual noises, other signs of malfunction
fasteners	<input type="checkbox"/> stripped threads, bent, worn, otherwise damaged	<input type="checkbox"/> loose, not tightened to proper torque
gearbox	<input type="checkbox"/> gears, bearings, or shafts loose, worn, otherwise damaged <input type="checkbox"/> oil leakage	<input type="checkbox"/> not properly lubricated <input type="checkbox"/> oil contaminated
wire rope	<input type="checkbox"/> bent, crushed, otherwise damaged <input type="checkbox"/> broken wires, see Figure 11 replace if more than 6 wires in one lay, or 3 wires in one strand in one lay, are broken <input type="checkbox"/> diameter reduced, see Figure 13 replace if diameter is excessively worn	<input type="checkbox"/> wire rope loosely or unevenly wound number per strand = number per lay = diameter =
end connections	<input type="checkbox"/> corroded, rusted, worn, otherwise damaged	<input type="checkbox"/> not securely attached
hook or other device	<input type="checkbox"/> twisted, bent, worn, otherwise damaged, see Figure 12 replace if twist is 10 degrees or more replace if throat width is 15% larger than nominal replace if thickness is 10% less than nominal	<input type="checkbox"/> hook latch fails to close when released twist = throat width = thickness =
drum	<input type="checkbox"/> anchor worn, distorted, otherwise damaged	<input type="checkbox"/> excessive movement or backlash
brake	<input type="checkbox"/> brake worn, corroded, otherwise damaged	<input type="checkbox"/> brake does not operate properly
labels and plates	<input type="checkbox"/> dirty, illegible, otherwise damaged	<input type="checkbox"/> loosely attached or missing

comments

authorized signature _____ **date** _____

Table 3 – Troubleshooting Chart

Contact the factory for detailed instructions on re-sealing the gearbox if you are required to disassemble the gearbox for any reason. Disassembly of the gearbox before contacting Thern, Inc. voids all warranties.

problem	cause	correction
handle turns, drum doesn't turn	• loose or broken spring pins or shafts	inspect winch and brake, repair as necessary
	• loose, stripped or broken gears or keys	repair as necessary
handle turns hard or not at all	• unit overheated	allow to cool
	• load too heavy	lighten load
	• gearbox contaminated with dirt or debris	inspect and relubricate as necessary
	• keys or spring pins loose or broken	inspect winch and brake, repair as necessary
	• brake band too tight	loosen brake and readjust
	• brake broken or locked	inspect and repair as necessary
	• gears or bearings broken or locked	inspect and replace as necessary
brake does not operate properly	• wire rope installed improperly	reinstall wire rope correctly
	• brake adjusted incorrectly	adjust brake
	• brake worn or damaged	inspect and replace as necessary
	• brake components broken or locked	inspect and repair as necessary
lubricant leakage	• worn bearings	inspect and replace as necessary
	• oil seals leaking or damaged	inspect and replace as necessary
	• gaskets leaking or damaged	tighten fasteners or replace gasket
	• cracked or damaged gearbox	inspect and repair as necessary
	• gearcase plugs not tightened	tighten
	• breather plug clogged or damaged	clean or replace vent plug as needed
excessive end play on drive shaft	• loose or damaged keys or keyways	inspect and replace as necessary
	• thrust washer or bearing worn out	inspect and replace as necessary
	• excessively worn gears	inspect and repair as necessary
excessively worn gears or bearings	• load too heavy	lighten load
	• poor lubrication of gears or bearings	inspect and lubricate as necessary
overheating	• operated too long without rest	allow to cool
	• load too heavy	lighten load
	• poor lubrication	inspect and lubricate as necessary
	• breather plug clogged or damaged	clean or replace vent plug as needed
	• bearing seized up	inspect and replace as necessary
unusual noises		
high pitched squeak	• poor lubrication	inspect and lubricate as necessary
grinding noise	• contaminated lubrication	drain, clean and lubricate the winch
	• dirt in winch gears	inspect and clean as necessary
	• broken gears or bearings	inspect and replace as necessary
rattling noise	• loose fasteners or set screws	tighten all fasteners and screws
heavy thump during operation	• contaminants in lubricant	drain, clean and lubricate the winch
	• loose set screws or keys in gears or shafts	inspect and repair as necessary
	• bearings defective	inspect and replace as necessary
back drive	• brake out of adjustment	adjust brake per manual

3.5 Repairing the Winch

Important!

- It is your responsibility to determine when to replace parts. When considering whether to continue using a part or to replace it, remember that replacing it is the best way to avoid further equipment damage.
- Replace spring pins, retaining rings, and oil seals whenever the winch is disassembled for inspection or repair.
- During reassembly, use **Loctite 598 Ultra Black** to create a seal between the two halves of the gearbox and the input shaft. Contact the factory for detailed instructions. Disassembly of the gearbox before contacting Thern, Inc. voids all warranties.
- Appoint a qualified person to be responsible for all repairs to the equipment.

- 3.5.1 GET FACTORY AUTHORIZATION for all repairs. Unauthorized repairs will void the warranty, and may lead to damage or failure of the winch.
- 3.5.2 REPLACE DAMAGED OR POORLY OPERATING PARTS with Thern repair parts.
- 3.5.3 REFINISH AREAS where the paint is worn or flaking. A good finish helps to protect against corrosion and weather damage.
 - a REMOVE THE FINISH from damaged areas, down to the bare metal.
 - b CLEAN THE AREA thoroughly.
 - c REPAINT with a high quality primer and finishing coat.
- 3.5.4 TO ORDER REPAIR PARTS, contact your local dealer. Include the following information when ordering:
 - model number
 - **serial number** (or code number)
 - part number
 - date purchased, and from whom
 - description of what happened, or what is wrong
 - your name and return address

4.1 Transporting the Winch

Important!

- Keep a record of what you ship, and when you send it.

- 4.1.1 REMOVE THE BREATHER PLUG and install a sealed oil plug to prevent the loss of lubrication during shipment.
- 4.1.2 PACK THE WINCH in an upright position for transport, using the original packaging materials, if possible.
 - a FASTEN THE WINCH to a wooden base using lag bolts, to keep it from moving during transport.
 - b SEAL THE WINCH in plastic with a desiccant to help protect it from rust, corrosion, and other damage.
 - c CONSTRUCT WOODEN SIDES and top to enclose the winch in a solid protective crate.
 - d PACK LOOSE PARTS in small boxes or ship separately.
- 4.1.3 INSPECT THE WINCH according to the Instructions for Periodic Inspection before installing it in a new location.

4.2 Storing the Winch

- 4.2.1 LUBRICATE THE WINCH as necessary, and make sure the breather plug is clean and properly installed. Add a rust preventative for long term storage.
- 4.2.2 SEAL THE WINCH in plastic with a desiccant to help protect it from rust, corrosion, and other damage.
- 4.2.3 STORE THE WINCH upright, in a cool clean place away from corrosive chemicals and moisture.
- 4.2.4 ROTATE THE DRUM PERIODICALLY to keep bearing and gears surfaces from becoming lacquered.
- 4.2.5 INSPECT THE WINCH according to the Instructions for Periodic Inspection before installing it for operation.
- 4.2.6 LUBRICATE THE WINCH PROPERLY prior to operation. Refer to Section 3.3 Lubricating the Winch.

Model 4WM2 Worm Gear Hand Winch			
item	description	part number	qty.
1	REDUCER ASSEMBLY	D2058	1
2	HEX INPUT ASSEMBLY	B3705	1
3	KEY .188 X .188 X 1.000	A7310	1
4	HANDLE MEDALLION ASSEMBLY	B4218	1
5	HEX NUT .375-16NC	A3017	6
6	SETSCREW SQHD .250-20NC X .875	A7536	1
7	DRUM	C3381	1
8	GROOVE PIN .312 X 2.500	A7284	1
9	FRAME	D1913	1
10	FLANGE BEARING	A7285	1
11	CARRIAGE BOLT .375-16NC X 1.250	A7283	2
12	BREATHER PLUG	A3408	1
13	LABEL WARNING DO NOT ADJUST BRAKE WHEN	A2658	1
14	NAMEPLATE	A6889	1
15	LABEL CODE NUMBER	10477	1
16	LABEL WARNING TO AVOID INJURY OR PROP...	A1978	1
17	LABEL WARNING KEEP HANDS AWAY FROM DRUM	A2659	2
18	LABEL WARNING	A7406	1
19	LABEL MODEL/CAPACITY	A7473	1

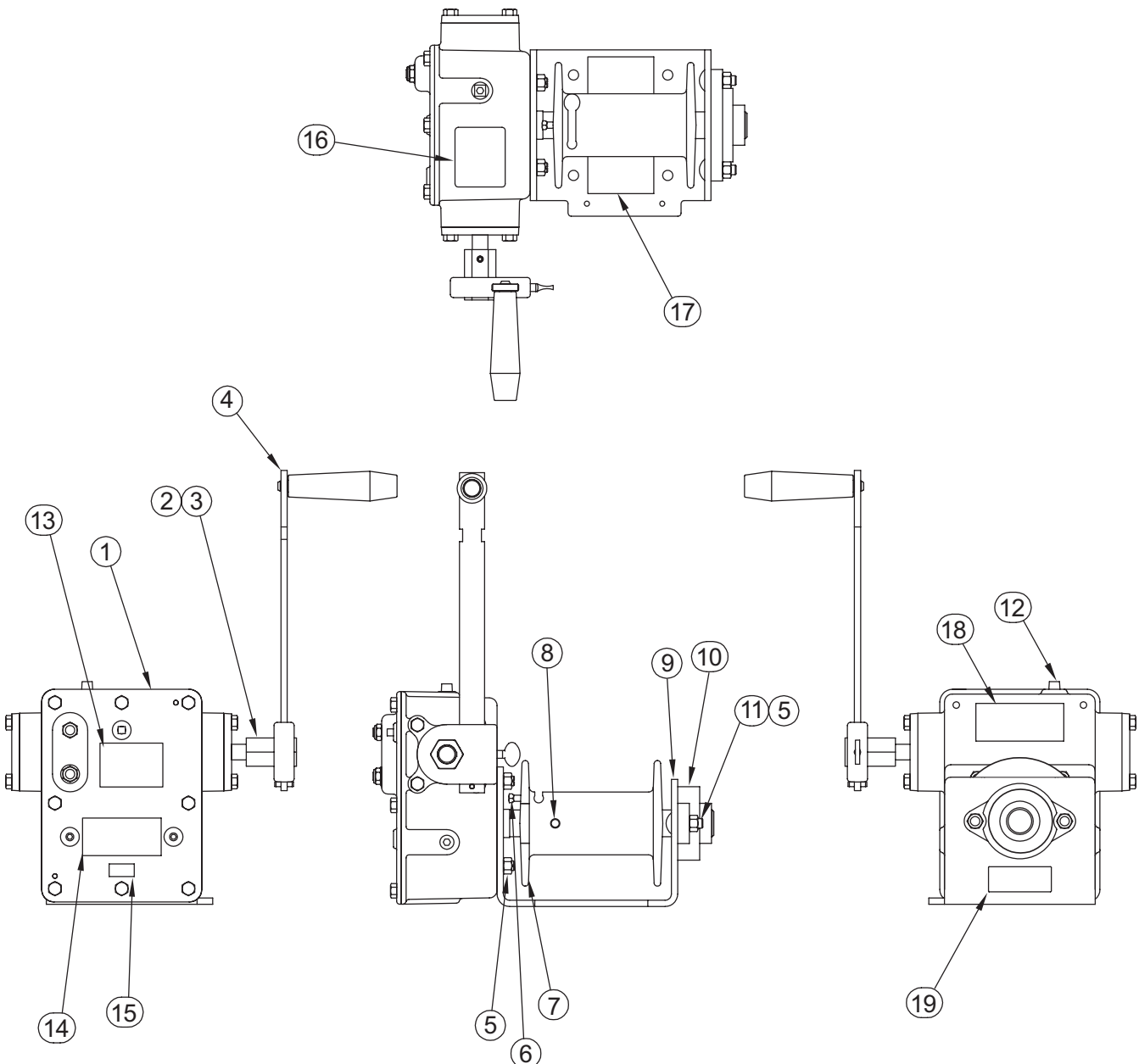

Model 4WM2V Worm Gear Hand Winch - Vertical Mount			
item	description	part number	qty.
1	REDUCER ASSEMBLY	D2058	1
2	HEX INPUT ASSEMBLY	B3705	1
3	KEY .188 X .188 X 1.000	A7310	1
4	HANDLE MEDALLION ASSEMBLY	B4218	1
5	HEX NUT .375-16NC	A3017	6
6	SETSCREW SQHD .250-20NC X .875	A7536	1
7	DRUM	C3381	1
8	GROOVE PIN .312 X 2.500	A7284	1
9	FRAME	D2173	1
10	FLANGE BEARING	A7285	1
11	CARRIAGE BOLT .375-16NC X 1.250	A7283	2
12	BREATHER PLUG	A3408	1
13	LABEL WARNING DO NOT ADJUST BRAKE WHEN	A2658	1
14	NAMEPLATE	A6889	1
15	LABEL CODE NUMBER	10477	1
16	LABEL WARNING TO AVOID INJURY OR PROP...	A1978	1
17	LABEL WARNING KEEP HANDS AWAY FROM DRUM	A2659	2
18	LABEL WARNING	A7406	1
19	LABEL MODEL/CAPACITY	A7473	

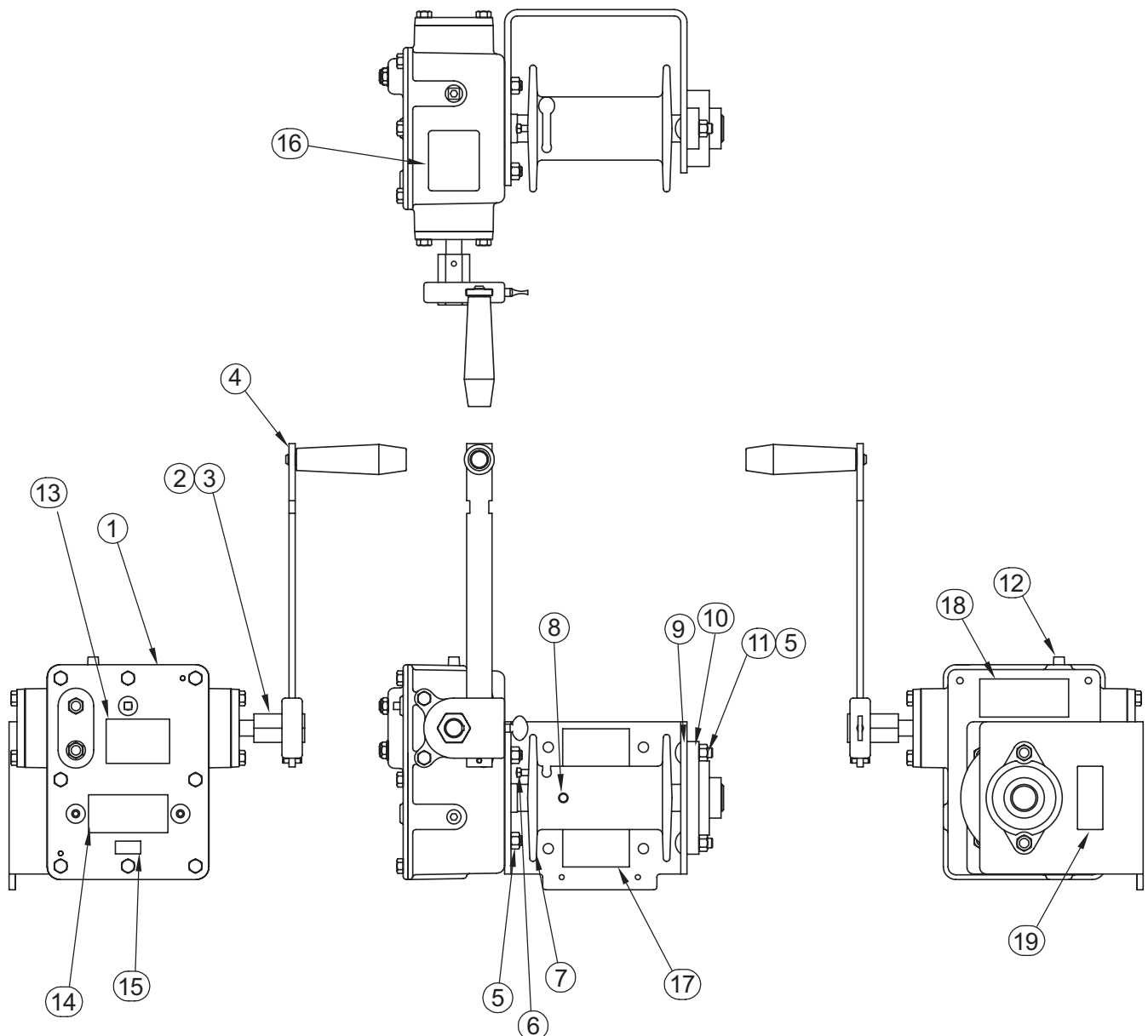

Reducer Assembly		D2058	
item	description	part number	qty.
1	CAPSCREW HEXHD .312-18NC X .750	A3032	12
2	BEARING HOUSING ASSEMBLY	B3582	1
3	BRAKE DRUM SPACER	A2642	2
4	THRUST BEARING .628ID X 1.250OD X .125	A7291	1
5	DRUM BRAKE ASSEMBLY	B1700	1
6	FLAT WASHER .656ID X 1.875OD X .094	A7292	2
7	SHIM .626/.630 X 1.00 X .018/.022	A3308	1
8	PIPE PLUG SQHD .125-27NPT X .35	A3407	1
9	DOWEL PIN .188 X .500	A7308	2
10	BALL THRUST BEARING .753ID X 1.685OD X .625	A1498	1
11	BEARING HOUSING ASSEMBLY INPUT SIDE	B3581	1
12	CAPSCREW HEXHD .312-18NC X 1.000	A3028	4
13	WORM SHAFT	C3276	1
14	PIPE PLUG HEXSOC .125-27NPT X .31	A3405	2
15	BRAKE BAND CONNECTOR ASSEMBLY	B2917	1
16	HEX JAM NUT NYLK .375-16NC	A3180	2
17	COVER	D2052RED	1
18	GEARCASE	D2051RED	1
19	STUD .375-16NC X 1.312	A7279	4
20	DRUM SHAFT ASSEMBLY	C3414	1
21	OIL SEAL 1.125ID X 1.874OD X .250	A7287	1
22	PIPE PLUG HEXSOC .375-18NPT X .425	A3290	4
23	SPRING WASHER .380 X .750 X .034	A3296	1

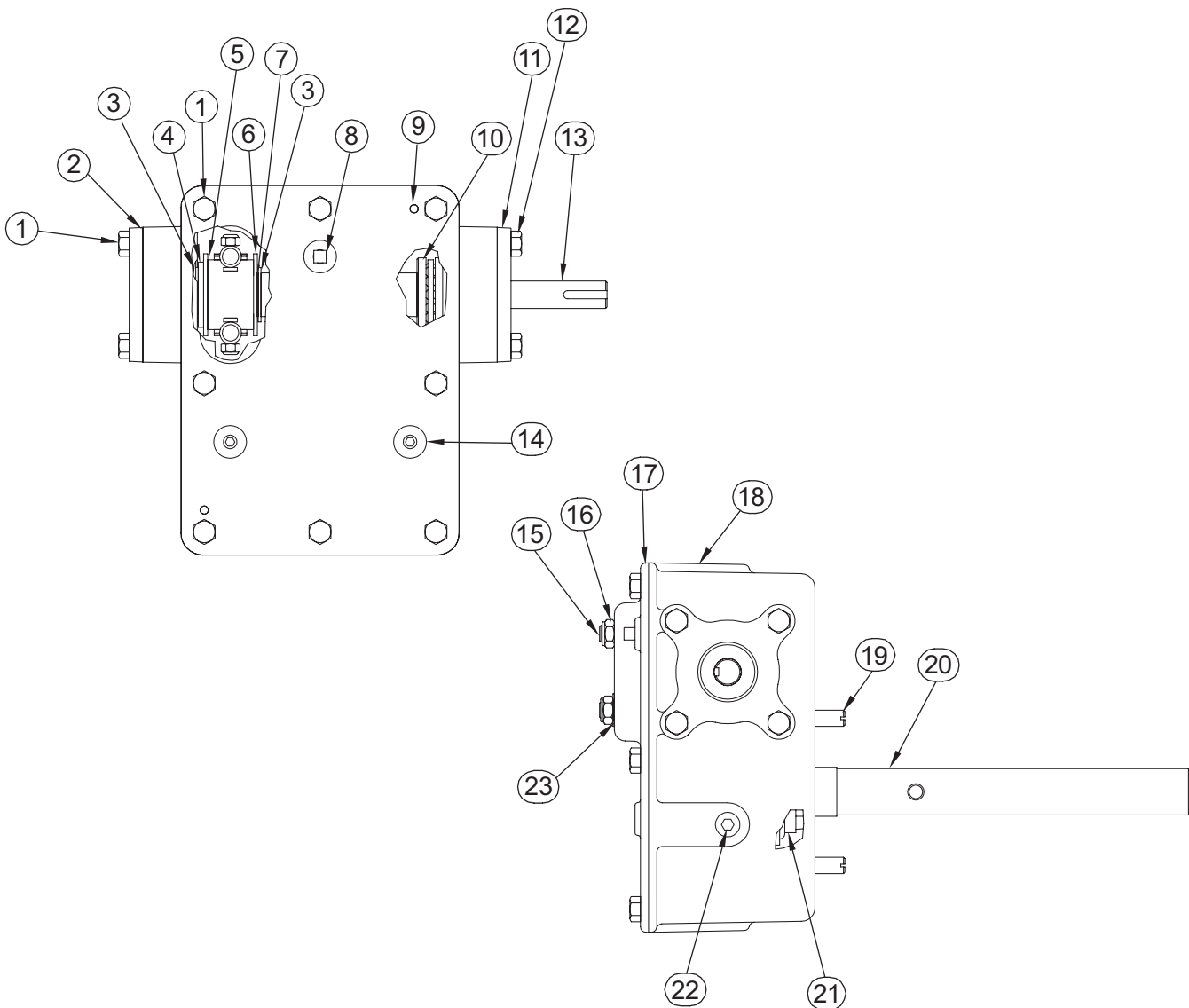

Pressure Plate Assembly ¹		B3688	
item	description	part number	qty.
1	PRESSURE PLATE	B3643	1
2	PIN	A3269	1
3	PRESSURE PLATE BASE	A3268	1
4	TORSION SPRING	A3277	1
5	SPACER TUBE	A3273	1
6	CAPSCREW HEXHD .250-20NC X .375	A7434	2
7	RETAINING RING .500	A3278	2

¹ B3688 supplied with crane winches 4WM2-K and 4WM2V-K.

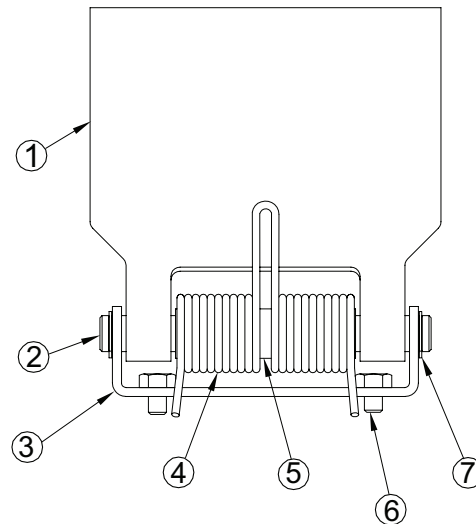

Handle Medallion Assembly		B4218	
item	description	part number	qty.
1	HANDLE ASSEMBLY	B4187	1
2	THUMB SCREW .312-18NC X .750 SST	A8167	1
3	MEDALLION	B4189	1
4	SLOTTED SPRING PIN .187 X .750 SST	A4282	1

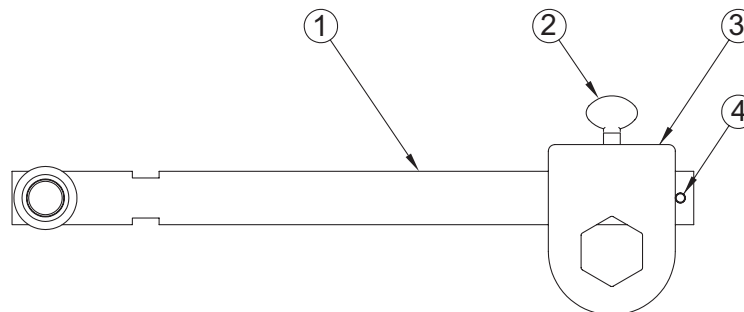

4WM2 Performance Characteristics ¹								
wire rope dia. (in)	load rating (lb)			drum capacity (ft)			gear ratio	force to lift 1000 lb
	1st layer	mid drum	full drum	1st layer	mid drum	full drum		
1/4	2000	1500	1200	11	35	77	32:1	14 lb
5/16	2000	1500	1200	8	23	52	32:1	14 lb

¹ Performance Characteristics are for standard products referred to in this manual. Non-standard products may vary from the original design. Contact Thern, Inc. for this information.



THERN

Thern, Incorporated

5712 Industrial Park Road
Winona, MN 55987

PH 507-454-2996

FAX 507-454-5282

EMAIL: info@thern.com

www.thern.com

Thern Europe

Bedrijvenpark Twente 454e
7602 KM Almelo
Netherlands

PH +31-546-898-380

EMAIL: europe@thern.com